

Airwork's guided compact cylinder CC series family is increased by a new version with a self-regulating pneumatic cushioning. It's an easy system that offers many advantages:

- it's a low cost cushioning system
- the end-stroke shock noise is totally removed
- thanks to the pneumatic cushioning it's possible to increase the speed rather than the standard version.

La famille de la série CC de Airwork est renforcée d'un nouvelle version avec un amortissement pneumatique avec auto-régulation. Il est un système simple qui offre de nombreux avantages:

- **Il est un système d'amortissement à faible coût**
- **Le bruit de choc de fin de course est totalement retirée**
- **Grâce à l'amortissement pneumatique, il est possible d'augmenter la vitesse plutôt que la version standard.**

Il cilindro compatto guidato serie 6 si arricchisce di una nuova versione con ammortizzo pneumatico autoregolante. È un sistema semplice che offre molti vantaggi:

- *è un sistema di ammortizzo low cost*
- *viene eliminato totalmente il rumore di fine corsa*
- *grazie all'ammortizzo pneumatico è possibile aumentare le velocità rispetto alla versione standard.*

ORDERING CODE / **CODIFICATION** / *CHIAVE DI CODIFICA*

CC404600000

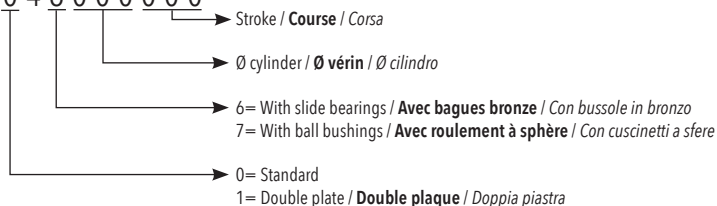

STANDARD STROKES / **COURSE STANDARD** / *CORSE STANDARD*

Ø16	mm 25-50-75
Ø20	mm 25-50-75-100-125-150-175
Ø25	mm 25-50-75-100-125-150-175
Ø32	mm 25-50-75-100-125-150-175
Ø40	mm 25-50-75-100-125-150-175
Ø50	mm 25-50-75-100-125-150-175
Ø63	mm 25-50-75-100-125-150-175

TECHNICAL DATA / **DONNÉES TECHNIQUES** / *DATI TECNICI*

Fluid / Fluide / <i>Fluido</i>	Lubricated or non lubricated air / Air lubrifié ou non lubrifié / <i>Aria con o senza lubrificazione</i>
Operating temperature range / Température d'utilisation / <i>Temperatura di esercizio</i>	Polyurethane / Polyuréthane / <i>Poliuretano</i> : -20°C / +80°C Polyurethane high temperature / Polyuréthane haute température / <i>Poliuretano alta temperatura</i> : -29°C / +120°C
Max operating pressure / Pression max d'utilisation / <i>Pressione massima di esercizio</i>	10 bar
Force / Force / <i>Forze sviluppate</i>	Technical informations page / Page informations techniques / <i>Pagina dati tecnici</i>
Air consumption / Consommation d'air / <i>Consumo aria</i>	Technical informations page / Page informations techniques / <i>Pagina dati tecnici</i>

FUNCTIONING / **FONCTIONNEMENT** / *FUNZIONAMENTO*

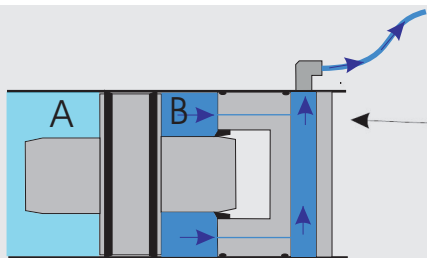

The compressed air in the chamber B, is discharged through the holes formed in the two heads.
L'air comprimé dans la chambre B, est purgé à travers les trous dans les deux têtes.
L'aria compressa all'interno della camera B viene scaricata attraverso due piccoli fori calibrati ricavati nella testata.

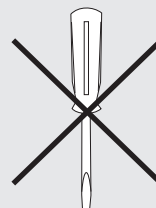
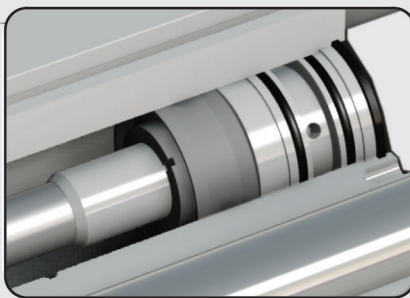

Manual adjustment is not necessary.
Réglage manuel n'est pas nécessaire.
Non è necessaria la regolazione manuale.

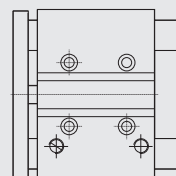

COMPONENTS / **COMPOSANTS** / COMPONENTI

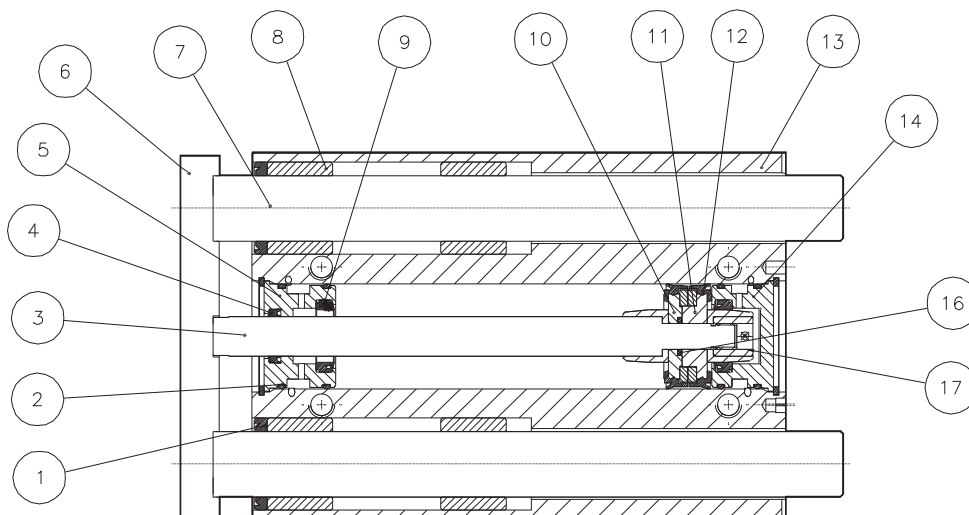
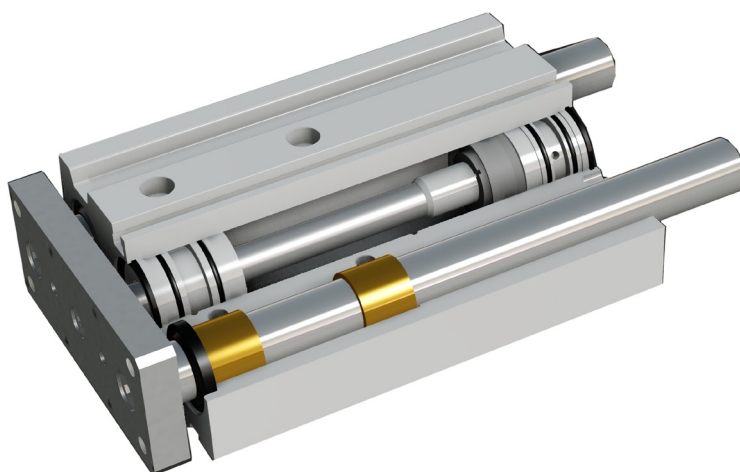

pos.	description / description / descrizione	material / matière / materiale
1	wiperod seal / joint de glissement / guarnizioni tergiasta	NBR
2	o-ring	NBR
3	rod / tige / stelo	steel C40 chromed / acier C40 chromé / acciaio C40 cromato
4	rod seal / joint tige / guarnizione stelo	polyurethane / PU / poliuretano
5	front cap / nez / testata anteriore	aluminium / aluminium / alluminio
6	plate / plaque / piastra	nickeled steel / acier nickelle / acciaio nichelato
7	guide rod / tige de guidage / stelo guida	steel C40 chromed / acier C40 chromé / acciaio C40 cromato steel C40 tempered / acier C40 trempé / acciaio C40 temprato
8	slide bearing / bagues bronze / bussole	bronze / bronze / bronzo
9	ball bushing / roulement à sphère / manicotti a sfera	steel / acier / acciaio
10	cushoning seal / joint amorti / guarnizione amm.	polyurethane / PU / poliuretano
11	semipiston / demi piston / semipistone	aluminium / aluminium / alluminio
12	semipiston / demi piston / semipistone	aluminium / aluminium / alluminio
13	seal piston / joint piston / guarnizione pistone	polyurethane / PU / poliuretano
14	body cylinder / corps / corpo cilindro	aluminium / aluminium / alluminio
16	rear cap / fond / testata posteriore	aluminium / aluminium / alluminio
17	o-ring	NBR
17	piston nut / écrou de piston / dado pistone	steel / acier / acciaio

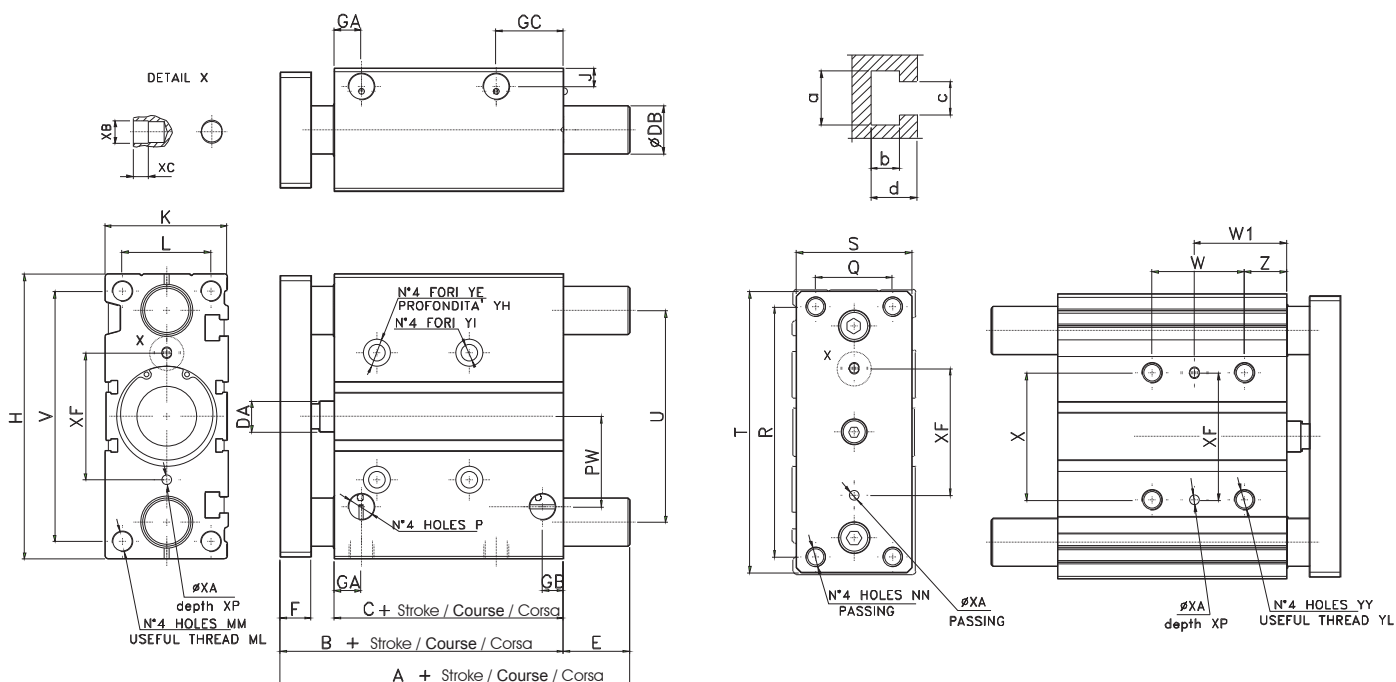

Ø	B	C	DA	F	GA	GB	GC	H	J	K	L	MM	ML	NN	P	PW	Q	R	S	T	U	V	X	YY	YL	YE	YH	YI	Z	XF	XA	XP	XB	XC	a	b	c	d
16	71	58	8	8	11	8	18	64	5	30	22	M5	12	M5	M5	19	16	54	25	62	46	56	24	M5	10	8	4.5	4.3	5	24	3	6	3.5	3	7.4	3.7	4.4	6.2
20	78	62	10	10	10.5	8.5	24.5	83	6.5	36	24	M5	13	M5	G1/8	25	18	70	30	81	54	72	28	M6	12	9.5	5.5	5.6	17	28	3	6	3.5	3	8.4	4.5	5.5	7.3
25	78.5	62.5	10	10	11.5	9	25	93	7.5	42	30	M6	15	M6	G1/8	28.5	26	78	38	91	64	82	34	M6	12	9.5	5.5	5.6	17	34	4	6	4.5	3	8.4	4.5	5.5	7.5
32	84.5	62.5	12	12	12.5	9	30.5	112	9	48	34	M8	20	M8	G1/8	34	30	96	44	110	78	98	42	M8	16	11	7.5	6.6	21	42	4	6	4.5	3	10.5	5.5	6.5	9
40	91	69	12	12	14	10	31	120	9	54	40	M8	20	M8	G1/8	38	30	104	44	118	86	106	50	M8	16	11	7.5	6.6	22	50	4	6	4.5	3	10.5	5.5	6.5	9
50	97	69	16	16	14	11	35	148	9.5	64	46	M10	22	M10	G1/4	47	40	130	60	146	110	130	66	M10	20	14	9	8.6	24	66	5	8	6	4	13.5	7.5	8.5	12
63	104	74	16	16	16.5	13.5	35	162	11	78	58	M10	22	M10	G1/4	55	50	130	70	158	110	142	80	M10	20	14	9	8.6	24	80	5	8	6	4	17.8	10	11	16.5

WITH SLIDE BEARINGS / AVEC BAGUES BRONZE / CON BUSSOLE IN BRONZO

Ø	A (stroke/course/corse)			E (stroke/course/corse)			DB
16	71 (25÷75)			0 (25÷75)			10
20	78 (25)	86.5 (50)	84.5 (75÷175)	0 (25)	8.5 (50)	6.5 (75÷175)	12
25	78.5 (25)	87 (50)	85 (75÷175)	0 (25)	8.5 (50)	6.5 (75÷175)	16
32	97 (25)	127 (50)	102 (75÷175)	12.5 (25)	42.5 (50)	17.5 (75÷175)	20
40	97 (25)	127 (50)	102 (75÷175)	6 (25)	36 (50)	11 (75÷175)	20
50	106.5 (25)	131.5 (50)	118 (75÷175)	9.5 (25)	34.5 (50)	21 (75÷175)	25
63	106.5 (25)	131.5 (50)	118 (75÷175)	4.5 (25)	29.5 (50)	16 (75÷175)	25

WITH BALL BUSHING / AVEC ROULEMENT À SPHÈRE / CON MANICOTTI A RICIRCOLO DI SFERE

Ø	A (stroke/course/corse)				E (stroke/course/corse)				DB	
16	71 (25÷75)				0 (25÷75)				8	
20	95 (25)	80 (50÷75)	99 (100)	104 (125÷175)	17 (25)	2 (50÷75)	21 (100)	26 (125÷175)	12	
25	100.5 (25)	85.5 (50÷75)	99.5 (100)	104.5 (125÷175)	22 (25)	7 (50÷75)	26 (100)	26 (125÷175)	12	
32	84.5 (25)	123 (50)	98 (75)	115.5 (100)	118 (125÷175)	0 (25)	38.5 (50)	13.5 (75)	31 (100)	33.5 (125÷175)
40	91 (25)	123 (50)	98 (75)	115.5 (100)	118 (125÷175)	0 (25)	32 (50)	7 (75)	24.5 (100)	27 (125÷175)
50	97 (25)	127.5 (50)	114 (75)	159 (100)	134 (125÷175)	0 (25)	30.5 (50)	17 (75)	62 (100)	37 (125÷175)
63	102 (25)	127.5 (50)	114 (75)	159 (100)	134 (125÷175)	0 (25)	25.5 (50)	12 (75)	57 (100)	32 (125÷175)

Ø	W (stroke/course/corse)		W1 (stroke/course/corse)	
16	44 (25÷75)		27 (25÷75)	
20	44 (25÷75)	120 (100÷175)	39 (25÷75)	77 (100÷175)
25	44 (25÷75)	120 (100÷175)	39 (25÷75)	77 (100÷175)
32	48 (25÷75)	124 (100÷175)	45 (25÷75)	83 (100÷175)
40	48 (25÷75)	124 (100÷175)	46 (25÷75)	84 (100÷175)
50	48 (25÷75)	124 (100÷175)	48 (25÷75)	86 (100÷175)
63	52 (25÷75)	128 (100÷175)	50 (25÷75)	88 (100÷175)