



Airwork rotary cylinders are engineered in order to transform the rectilinear motion, typical of the pneumatic cylinders, into a rotating motion equipped with torque.

Available from diameter 32 to 125 mm, they are supplied with pneumatic cushioning and the spin angle can be adjusted of about 10°.

A special regulation, by using a guide rail, reduces the clearance between pinion and rack.

Le vérin rotatif d'Airwork est spécialement conçu pour transformer le mouvement rectiligne, typique d'un vérin pneumatique, en mouvement rotatif avec torsion.

Disponibles du diamètre 32 mm à 125mm, ils ont un amorti pneumatique et différentes versions et accessoires. Possibilité de faire des angles de rotation spéciaux, et de réduire le dégagement entre pignon et support.

I cilindri rotanti Airwork sono stati concepiti per trasformare il moto rettilineo, tipico dei cilindri pneumatici, in moto rotatorio dotato di coppia torcente. Sono forniti con ammortizzo pneumatico ed hanno la possibilità di regolare l'angolo di rotazione di circa 10°. Una speciale regolazione, mediante pattino guida, riduce al minimo il gioco tra pignone e cremagliera. Su richiesta vengono fornite rotazioni speciali.

ORDERING CODE / **CODIFICATION** / **CHIAVE DI CODIFICA**

R Y 0 0 1 0 0 0 0 0 0

→ Angle of rotation / **Angle de rotation** / *Angolo di rotazione*

→ Ø cylinder / **Ø vérin** / *Ø cilindro*

→ VERSION / **VERSION** / *VERSIONE*

01= Male pinion with adjustment magnetic / **Pignon mâle avec ajustement magnétique** /

Pignone maschio con regolazione magnetico

03= Female pinion with adjustment magnetic / **Pignon femelle avec ajustement magnétique** /

Pignone femmina con regolazione magnetico

05= Male pinion without adjustment magnetic / **Pignon mâle sans ajustement magnétique** /

Pignone maschio senza regolazione magnetico

07= Female pinion without adjustment magnetic / **Pignon femelle sans ajustement magnétique** /

Pignone femmina senza regolazione magnetico

VERSION / **VERSION** / *VERSIONE*

01



03



05



07



TECHNICAL DATA / **DONNÉES TECHNIQUES** / **DATI TECNICI**

Sizes / **Taille** / *Taglie*

Ø32-40-50-63-80-100-125

Standard rotations / **Rotation standard** / *Rotazioni standard*

90° - 180° - 270° - 360°

Fluid / **Fluide** / *Fluido*

Lubricated or non lubricated air / **Air avec ou sans lubrification** / *Aria con o senza lubrificazione*

Operating temperature range / **Température d'utilisation** / *Temperatura di esercizio*

-5°C / +80°C

Max operating pressure / **Pression max d'utilisation** / *Pressione massima di esercizio*

10 bar

Adjustment angle / **Ajustement de rotation** / *Regolazione angolo*

10°

COMPONENTS / **COMPOSANTS** / **COMPONENTI**

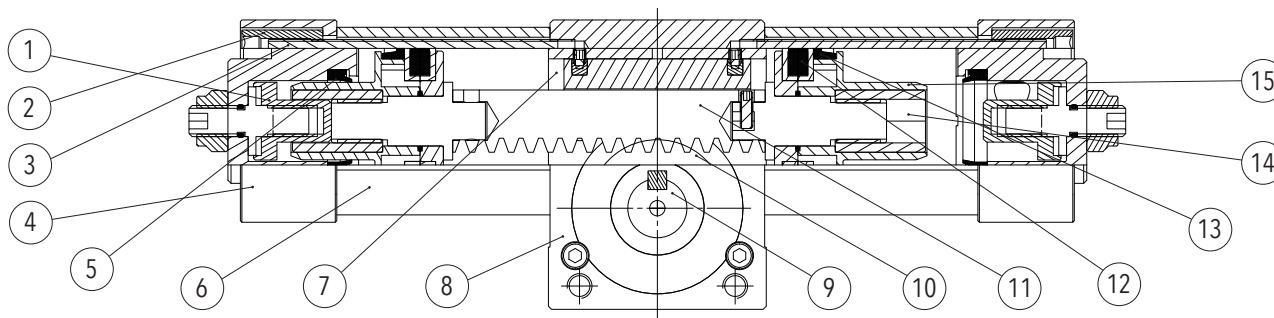

pos. description / **description** / *descrizione* material / **matériel** / *materiale*

1 regulator screw / **vis de regulation** / *vite di regolazione*

steel / **acier** / *acciaio*

2 nut / **écrou** / *dado*

steel / **acier** / *acciaio*

3 rod / **tirant** / *tirante*

steel / **acier** / *acciaio*

4 cap / **nez** / *testata*

aluminium / **aluminium** / *alluminio*

5 cushion seal / **joint amort.** / *guarnizione amm.*

polyurethane / **PU** / *poliuretano*

6 tube / **tube** / *tube*

aluminium / **aluminium** / *alluminio*

7 guide for rack / **guide crémaillère** / *guida cremagliera*

Delring

8 body / **corps** / *corpo*

aluminium / **aluminium** / *alluminio*

9 pinion / **pignon** / *pignone*

steel / **acier** / *acciaio*

10 ball bearings / **boisseau sphérique** / *cuscinetto a sfera*

steel / **acier** / *acciaio*

11 rack / **crémaillère** / *cremagliera*

steel / **acier** / *acciaio*

12 magnet / **aimant** / *magnete*

plastroferrite

13 seal piston / **joints piston** / *guarnizione pistone*

polyurethane / **PU** / *poliuretano*

14 nut / **écrou** / *dado*

steel / **acier** / *acciaio*

15 piston / **piston** / *pistone*

Delring

ADMISSIBLE LOAD / CHARGE ADMISSIBLE / CARICO AMMISSIBILE

MAX RADIAL LOAD F1 WITH F=0
CHARGE RADIALE MAX F1 AVEC F=0
CARICO RADIALE MASSIMO F1 CON F=0

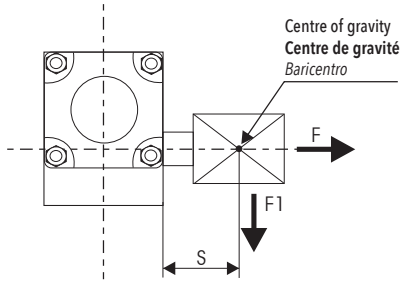

MAX AXIAL LOAD F WITH F1 = 0
CHARGE AXIALE F MAX CON F1 = 0
CARICO ASSIALE F MAX CON F1 = 0

	F (N)
Ø32	100 N
Ø40	100N
Ø50	120N
Ø63	120N
Ø80	200N
Ø100	250N
Ø125	300N

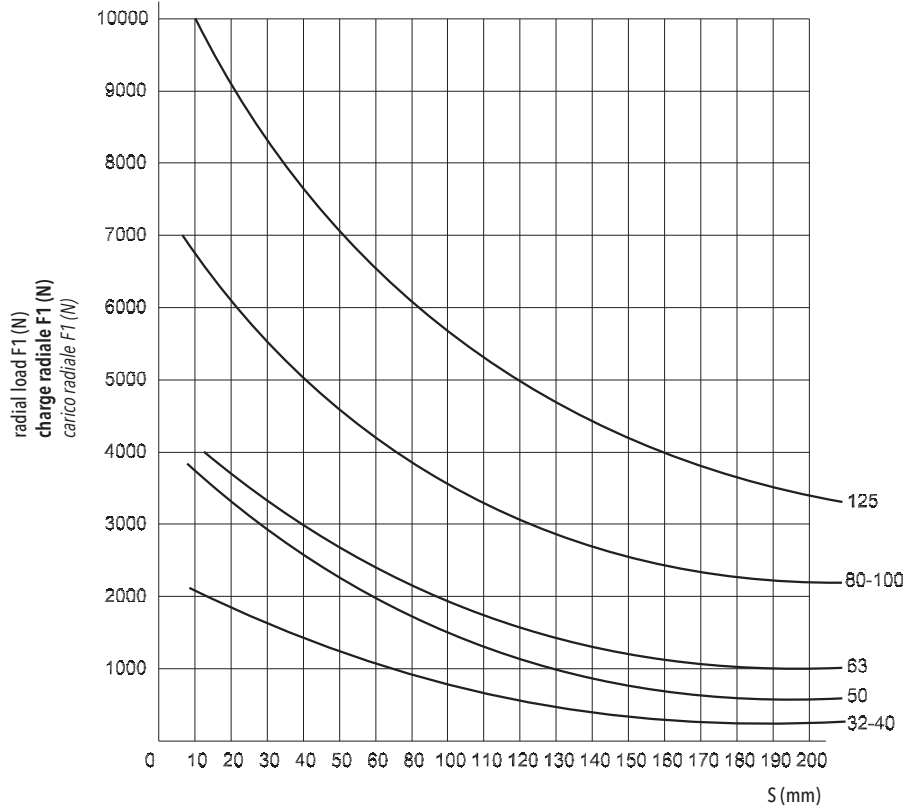

TORQUE A 1 BAR / MOUVEMENT DE TORSION A 1 BAR / MOMENTO TORCENTE AD 1 BAR

Ø32	1.2Nm
Ø40	2.25 Nm
Ø50	3.9 Nm
Ø63	7.3 Nm
Ø80	15.7 Nm
Ø100	26.35 Nm
Ø125	51 Nm

ADJUSTABLE ANGLE / ANGLE DE REGULATION / CAMPI DI REGOLAZIONI ANGOLO

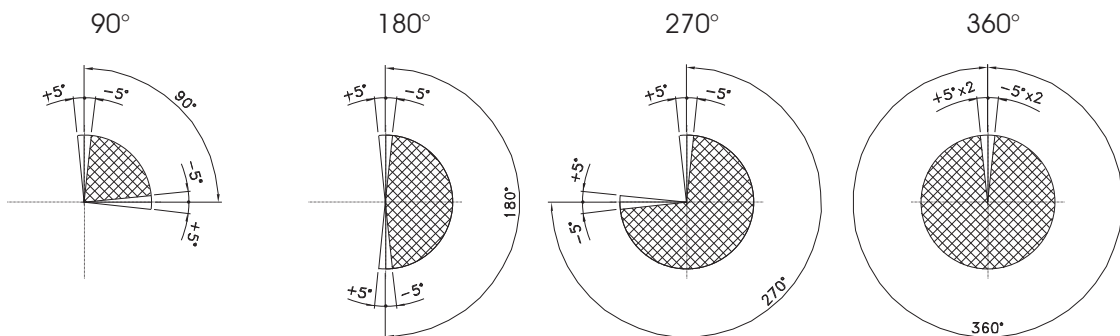

Rotary cylinder male pinion with rotation adjustment
Vérin rotatif pignon mâle avec régulation
Cilindro rotante pignone maschio con regolazione

CODE: RY011.Ø.0°

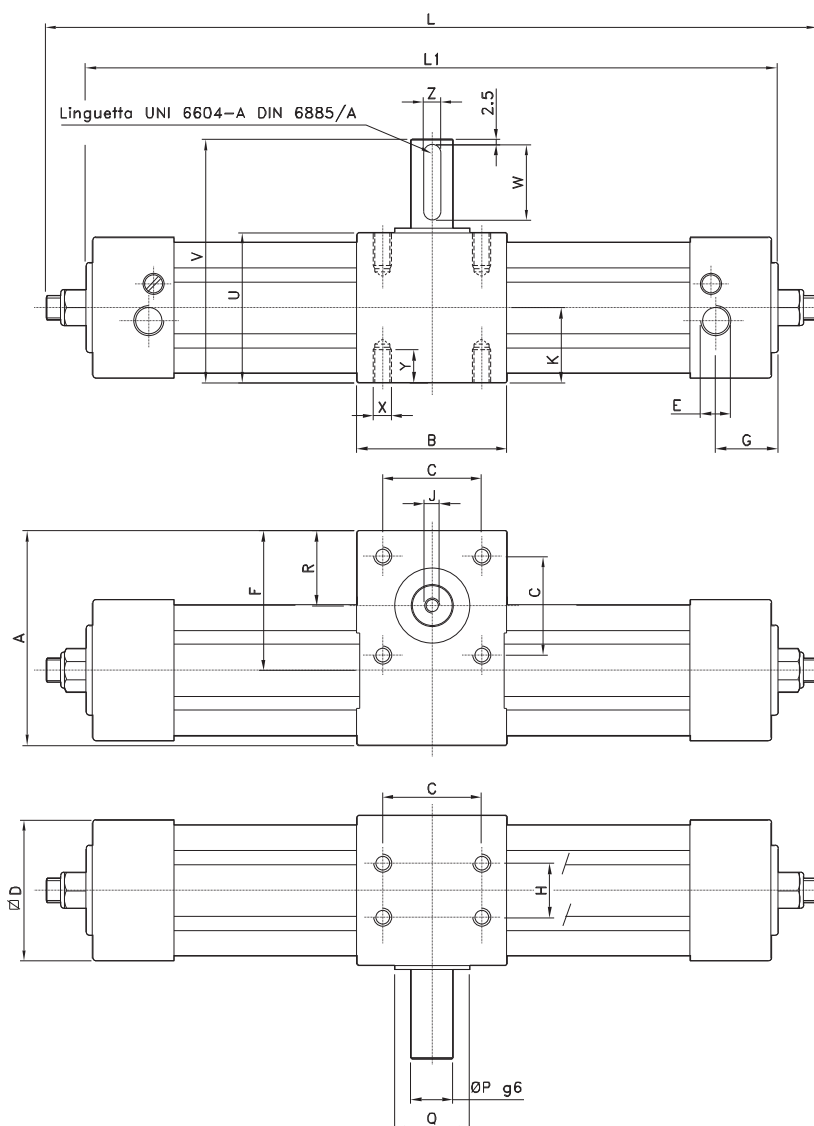

Ø	A	B	C	D	E	F	G	H	J	K	P	Q	R	U	V	X	Y	Z	W
32	71.5	50	33	48	1/8"G	46.5	18	18	M5	25	14	25	25	50	81	M6	10	5	25
40	82	60	40	54	1/4"G	54.5	21	22	M5	30	14	25	30	60	91	M6	10	5	25
50	93	70	50	67	1/4"G	60.5	24	25	M6	32.5	19	30	32.5	65	106	M8	13	6	35
63	109	75	60	78	3/8"G	70.8	26	35	M8	37.5	24	30	37	75	116	M8	13	8	35
80	142	99	80	97	3/8"G	93.5	26	50	M8	49.5	28	45	50	99	150	M10	16	8	45
100	156.5	115	80	115	1/2"G	99	30	60	M10	57.5	38	50	54	115	166	M10	16	10	45
125	188	125	90	140	1/2"G	118	32	70	M10	70	38	60	60	140	191	M12	20	10	45

Dimensions L and L1 for standard rotations

Dimensions L et L1 pour des rotations standard

Dimensioni L e L1 per rotazioni standard

Ø	90°		180°		270°		360°	
	L	L1	L	L1	L	L1	L	L1
32	232	213	279	260	326	307	373	354
40	274	254	330	310	387	367	464	424
50	301	276	364	339	427	402	489	464
63	343	320	418	395	493	470	567	544
80	416	386	515	485	614	584	713	683
100	449	418	556	525	662	631	769	738
125	518	487	650	619	782	751	914	883

Rotary cylinder female pinion with rotation adjustment
Vérin rotatif pignon femelle avec régulation
Cilindro rotante pignone femmina con regolazione

CODE: RY031.0.0°

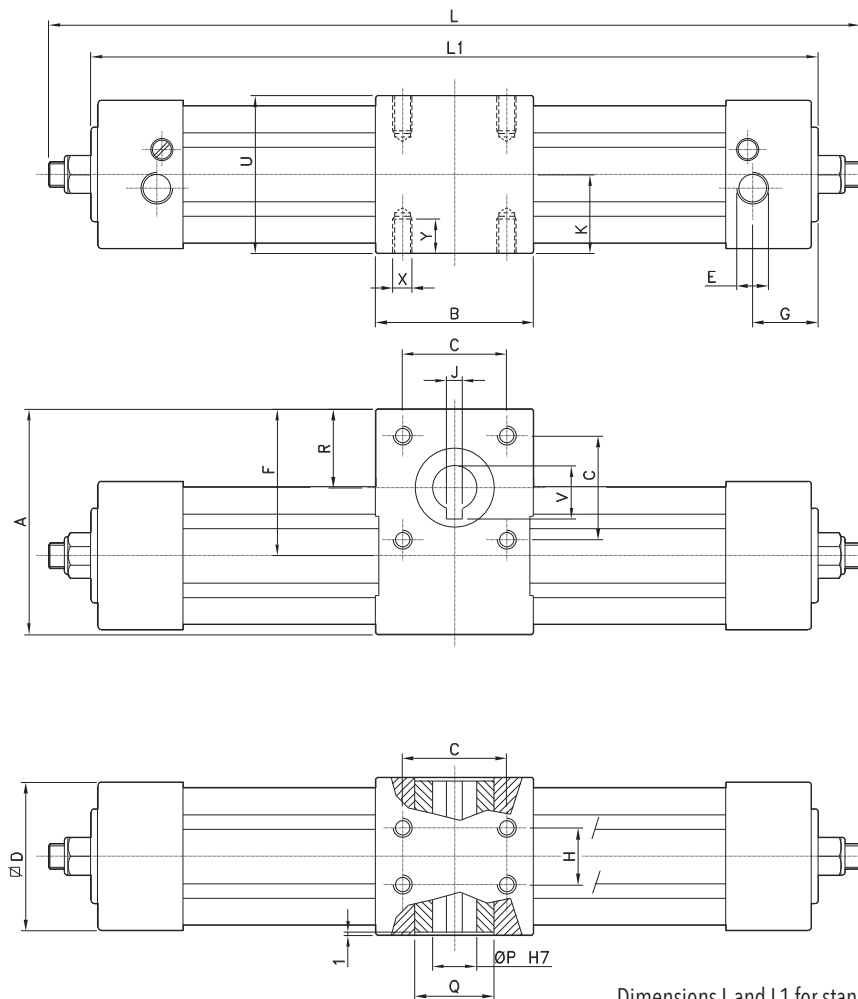

Dimensions L and L1 for standard rotations
Dimensions L et L1 pour des rotations standard
Dimensioni L e L1 per rotazioni standard

Ø	A	B	C	D	E	F	G	H	J	K	P	Q	R	U	V	X	Y
32	71.5	50	33	48	1/8"G	46.5	18	18	5	25	14	25	25	50	16.3	M6	10
40	82	60	40	54	1/4"G	54.5	21	22	5	30	14	25	30	60	16.3	M6	10
50	93	70	50	67	1/4"G	60.5	24	25	6	32.5	19	30	32.5	65	21.8	M8	13
53	109	75	60	78	3/8"G	70.8	26	35	6	37.5	19	30	37	75	21.8	M8	13
80	142	99	80	97	3/8"G	93.5	26	50	8	49.5	24	45	50	99	27.3	M10	16
100	156.5	115	80	115	1/2"G	99	30	60	8	57.5	28	50	54	115	31.3	M10	16
125	188	125	90	140	1/2"G	118	32	70	8	70	28	60	60	140	31.3	M12	20

Ø	90°		180°		270°		360°	
	L	L1	L	L1	L	L1	L	L1
32	232	213	279	260	326	307	373	354
40	274	254	330	310	387	367	464	424
50	301	276	364	339	427	402	489	464
63	343	320	418	395	493	470	567	544
80	416	386	515	485	614	584	713	683
100	449	418	556	525	662	631	769	738
125	518	487	650	619	782	751	914	883

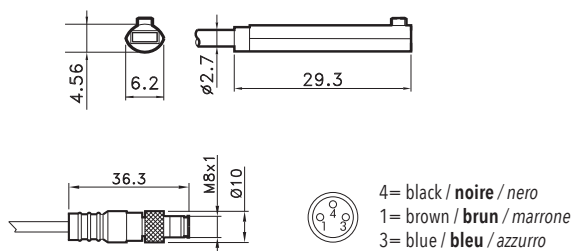

OVAL SWITCH / **CAPTEUR OVAL** / **SENSORE OVALE**

CODE

- AR4019010 REED (MT.2,5) / **REED (MT.2,5)** / REED (MT.2,5)
- AR4019020 HALL (MT.2,5) / **HALL (MT.2,5)** / HALL (MT.2,5)
- AR4019110 REED + M8 (CM 30) / **REED + M8** / REED + M8 (CM 30)
- AR4019120 HALL + M8 (CM 30) / **HALL + M8** / HALL + M8 (CM 30)

For technical data see page 1.61
Pour les données techniques, voir page 1.61
Per i dati tecnici vedere pag. 1.61