

TECHNICAL DATA / DONNÉES TECHNIQUES / DATI TECNICI

Fluid / Fluide / <i>Fluido</i>	Air / Air / <i>Aria</i>		
Maximum pressure / Pression Max / <i>Pressione Max</i>	15 bar		
Temperature / Température / <i>Temperatura</i>	-10° C / +50° C		
6 bar flow rate with Δp 1bar / Débit à 6 bar avec Δp à 1bar / <i>Portata a 6 bar con Δp 1bar</i>	1=1850 NI/min	2=3000NI/min	3=5200NI/min
Wall clamping screws / Vis pour fixation / <i>Viti per fissaggio</i>	1=M4X14	2=M5X18	3=M6X20
Solenoid / Solénoïde / <i>Solenoido</i>	24V DC 3W - 220V AC 5VA		

STANDARD PRODUCTS / PRODUIT STANDARD / PRODOTTI STANDARD

Code Code <i>Codice</i>	Size Taille <i>Taglia</i>	Thread Filetage <i>Filetto</i>	Drive Commande <i>Comando</i>
XA1300	1	3/8	EP
XA2300	2	3/8	EP
XA2400	2	1/2	EP
XA3500	3	3/4	EP
XA3600	3	1"	EP

EP: Electropneumatic (without coil) / **Electro pneumatique (sans bobine)** / *Elettropneumatico (senza bobina)*

SIZE 1 / TAILLE 1 / TAGLIA 1

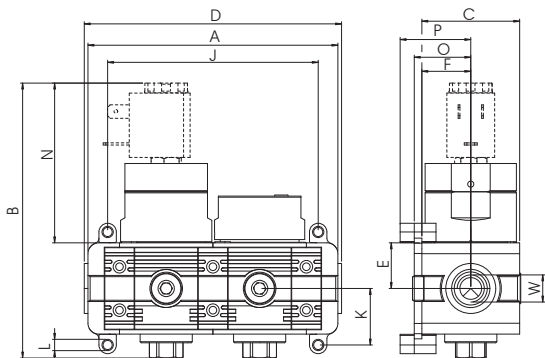

	1
A	118,5
B	126,5
C	45
D	115
W	1/8 - 1/4 - 3/8
E	21
F	22,5
J	97
K	26
L	Ø X M5
N	73,5
O	26
P	32,5

SIZE 2 - 3 / TAILLE 2 - 3 / TAGLIA 2 - 3

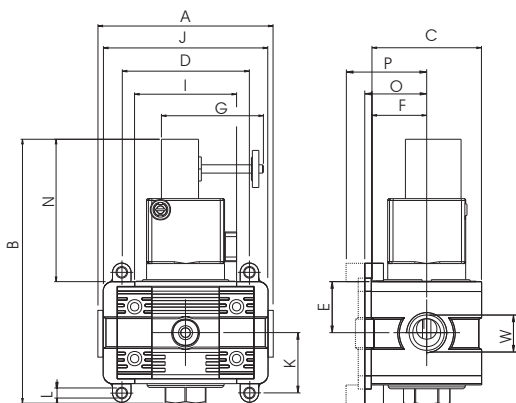

	2	3
A	89	106
B	142	131,5
C	59	70
D	89	100
W	1/4 - 3/8 - 1/2	1/2 - 3/4 - 1"
E	27,5	32,5
F	28,5	35
G	55,5	55,5
I	55	65
J	69	79
K	32,5	38
L	Ø X M5	Ø X M5
N	76,5	76,5
O	32	38,5
P	38,5	45